

5000L 2.5m diameter Collection Well



5000Litre 2.5m diameter
concrete collection well



Weight 4100kg



To collect sullage water from a septic tank for disposal by:

- Periodic removal by vacuum tanker
- Pump to disposal area/trench/sewer



Suitable for use as a water tank or
Onsite Detention Tank (OSD)



LOCKABLE & LIGHTWEIGHT
composite resin access cover:

- Weigh only 8.5kg and easy to lift
- Lockable with removable turnkey
- Sealed to prevent the ingress of surface water
- Access turret can be extended to increase fall into tank



Manufactured from 40mpa wet cast
concrete with fibre steel reinforcing



150mm concrete lid tested
to 3000kg:

- Reinforced with F82 steel mesh
- Access cover top load limit – 510kg



Installation:

- Top of turret lid can be flush with finished ground level
- Provide 75mm level bed of aggregate under tank

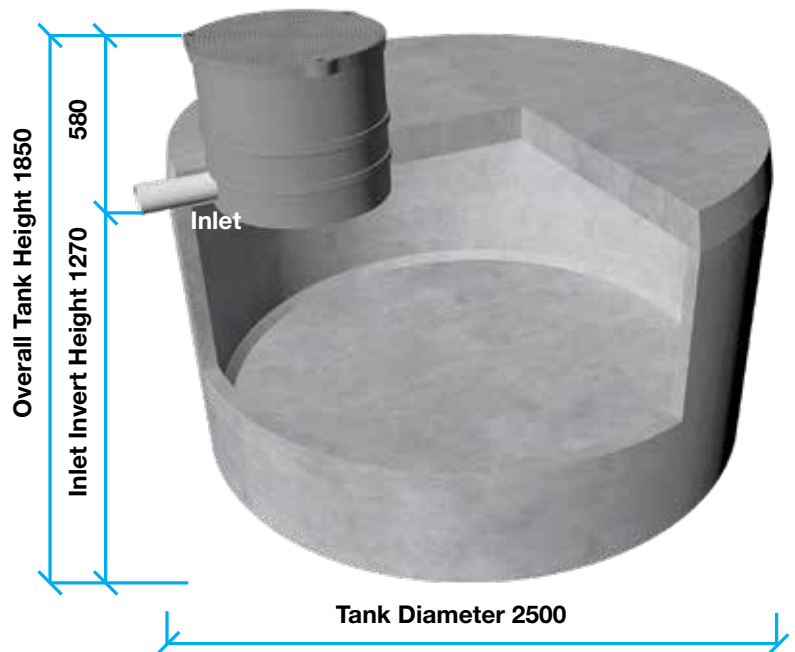

NSW Ministry
of Health
Certificate
of Accreditation
003-21556

67 Smeaton Grange Road,
Smeaton Grange, NSW 2567
EMAIL sales@bioseptic.com.au
ABN 95 056 461 226

BIOSEPTIC

PHONE 1300 658 111